

# IMM Quality Boat Lifts

## PWC 1500 SPECIFICATIONS

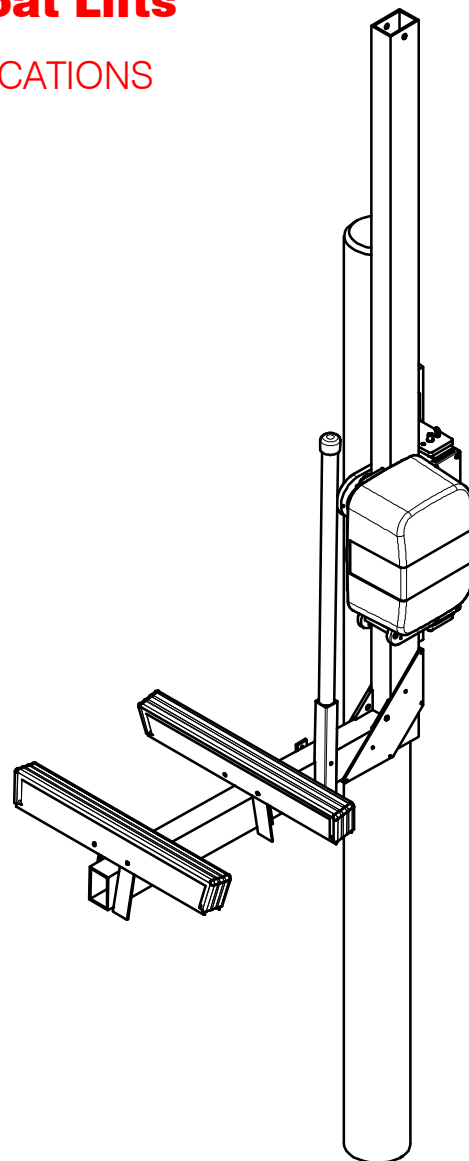
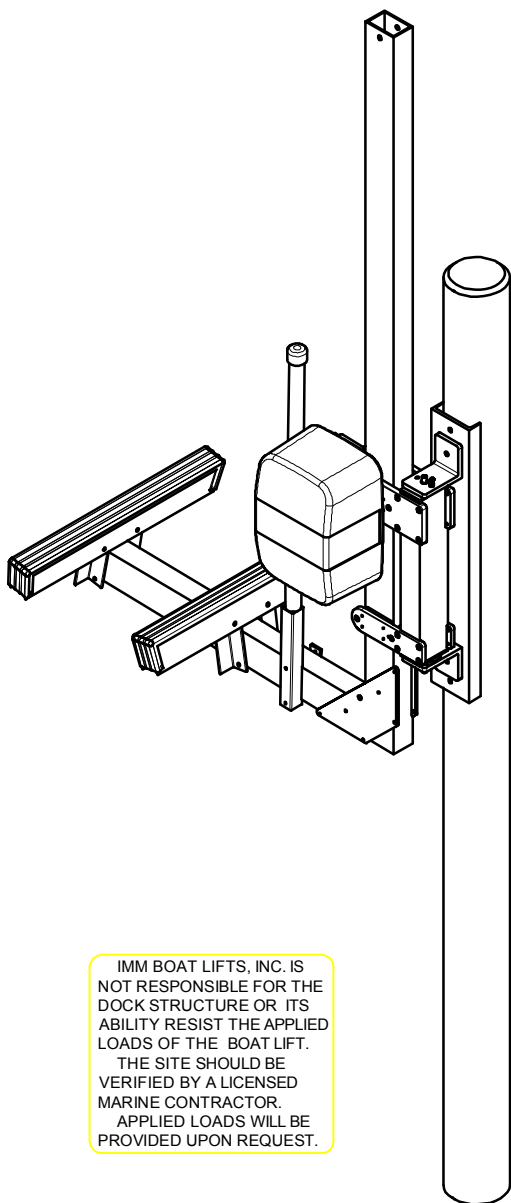

IMM BOAT LIFTS, INC. IS NOT RESPONSIBLE FOR THE DOCK STRUCTURE OR ITS ABILITY RESIST THE APPLIED LOADS OF THE BOAT LIFT. THE SITE SHOULD BE VERIFIED BY A LICENSED MARINE CONTRACTOR. APPLIED LOADS WILL BE PROVIDED UPON REQUEST.

LIFT CAPACITY lbs.	CRADLE TUBE 6061-T6	STD. TRACK I-BEAM 6061-T6	PILE SIZE mm.	GROOVED CABLE WINDER SIZE	MAX TRAVEL	CABLES	DRIVE SHAFT SIZE inches	GUIDE POST HEIGHT	BUNKS ALUM	DRIVE SHAFT SPROCKET	GEAR DRIVE SPROCKET	GEAR RATIO	MOTOR	LIFT SPEED in/min
1,500	6"x4"x.25"	6 x .21 H 4 x .35 W 15'	10"Ø	4" Nylon	77"	1/4 SSAC 7x19 304 1P 17	Tube 1.9 O.D. 9 Gauge	48"	72"	#50A60	#50B9	60:1	3/4H.P.-115V/11A 230V/5.5A	55

### Notes:

1. Structure designed for loads associated with an ultimate wind speed of 170 MPH, exposure 'D', risk category 1, calculated for Florida Building Code 2010, ASCE 7-10 and ADM-2005.
2. Boats shall not be stored on lifts during high wind events.
3. All primary structural members to be 6061-T6 aluminum.
4. Tracks are to be driven to firm bearing material.
5. Wood piles shall comply with ASTM D25 and be southern pine, 2.5 cca marine grade pressure treated.
6. Lateral support for piles and attachment to piles shall be engineered by others for site specific conditions.



DWG: G00111