

IMM QUALITY

— BOAT LIFTS —

Installation Manual

For

Alumavator / Platinum

Vertical Boat Lifts



Safety Precautions



1. Your boat lift is a heavy duty piece of equipment. It is important that all persons that may operate this unit have read and understood the owner's manual. Given the inherent dangers of heavy machinery, your boat lift deserves respect, and good judgment is required in its operation. Before allowing others to operate the unit be certain that they understand the proper operating procedures. Do not allow children to operate the lift.
2. This product is for lifting unoccupied boats. Do not ride in your boat or on the lift during operation. Always attend the controls when operating the lift, and watch carefully to have others stand clear. Keep hands, feet, and clothing away from all moving parts.
3. Your lift is operated by electricity, therefore, additional care must be taken. It must be wired by a licensed electrician, and it must be installed with an approved ground fault interruption device. If you observe severed or damaged wiring, it must be repaired immediately by an electrician. When properly installed and maintained, electrical devices such as this lift are completely safe. However, any electrical device used in and around a water environment must be treated with great respect to prevent accidental electrocution. All electrical maintenance and service to this lift must be done by a licensed electrician.
4. While operating your lift, routinely look at all cables for fraying, damaged ends, or loose strands. A damaged cable must be replaced immediately. Make sure that all pulleys are turning properly. Routinely look over cables to make sure that they are winding properly. Look for signs of extreme wear and unusual corrosion, as well as, exposed or damaged electrical wires. If you find any of the above, have the problem repaired immediately.
5. Do not work on your boat or lift while the boat is hoisted. When working on your lift, keep your hands, feet, and clothing away from all moving parts. Exercise great care if chains or gearing are exposed. Never work underneath a raised lift, and do not walk or stand on a raised lift. Always disconnect electrical power when working on any part of the lift.
6. Be careful not to exceed the rated capacity of the lift. To determine the total weight of your equipment to be lifted, study the boat manufacturer's literature to determine its weight. Be sure to add enough extra weight to compensate for your added accessories, including water and fuel. Gasoline weighs about 6 lbs. per gallon and water weighs about 8 lbs. per gallon.
7. If you plan to leave your lifted boat unattended for several weeks, it is important that you remove the drain plug in the boat to prevent it from filling with rain water. Accumulated rain, snow or other water in your boat can rapidly become heavy enough to exceed the capacity of a lift, causing personal injury or damage to the boat and lift.

Welcome, and congratulations on your purchase of an Imm Quality Boat Lift! At Imm Quality Boat Lifts, we take pride in making the most advanced, most durable, easy to use and low maintenance boat lifts on the market today. The installation of this lift is simplified by its' lightweight aluminum construction and by extensive factory assembly. Only Imm Quality takes the extra time to pre-wind the cable on the winders, attach the drives, motors and covers, and pre-assemble the mounting brackets, bunk brackets and guide post assembly. We do all this as an added service to make life easier for our valuable customers. In the following pages, we will take you step-by-step through the entire installation process. We urge you to read this manual before attempting installation. If you have any questions, please contact us at 1-800-545-5603 and ask for technical support.

Required Tools for Installation

- Chain Saw
- 10 " Level
- 2' Level
- 9/16" and 1/2" Open End Box Wrenches (2 each)
- 7/16" and 3/4" Open End Box Wrenches
- Phillips screwdriver
- Flat head screwdriver
- 1/2" Drive Ratchet
- 9/16", 1/2" and 3/4" Deep Well Sockets
- PVC Pipe Cutter
- Electricians Pliers
- Claw Hammer
- Cable Cutter
- 3/8" Battery Operated Drill
- 3/16" and 1/2" Drill Bits
- 36' Industrial Extension Ladder in two 18' Sections
- 2"x8"x16' Scaffold Boards (2) and 1"x6"x16' Scaffold Boards (4)
- Water Level

Before you begin...

The pilings are the foundation of the boat lift and must be able to carry the combined load of the lift and the fully loaded boat. Local and National building code and common practice varies from area to area. Consult with our technical service department or your local marine contractor for appropriate guidelines. We have included charts of typical pile spacing for your convenience.

4 Pile Lifts

ALL SPACING TO CENTER OF PILING

LIFT CAPACITY	A	B	C	RECOMMENDED Min. PILE SIZE
4,500 lbs.	132"	120"	178"	8" DIA.
7,000 lbs.	144"	144"	204"	8" DIA.
10,000 lbs.	144"	150"	208"	8" DIA.
13,000 lbs.	144"	150"	208"	8" DIA.
16,000 lbs.	144"	168"	218"	10" DIA.
16,000 XL lbs.	168"	168"	238"	10" DIA.
20,000 lbs.	168"	192"	255"	10" DIA.
27,000 lbs.	192"	192"	272"	10" DIA.

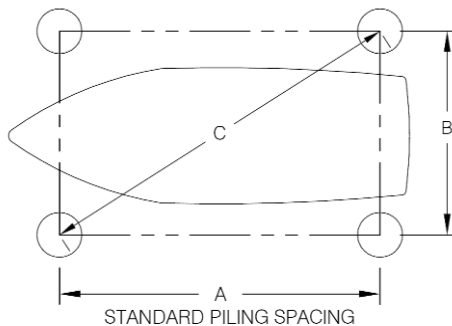

8 Pile Lifts

ALL SPACING TO CENTER OF PILING

Lift Capacity	A	B	C	D	Rec. min. Pile size
32,000 lb.	84"	216"	231.75"	*	10" dia.
40,000 lb.	84"	216"	231.75"	*	10" dia.
54,000 lb.	84"	240"	254.25"	*	10" dia.

Note: all Dimensions $\pm 2"$

*Standard spacing for dimension 'D' is 288".
Dimension 'D' dependent on boat length.

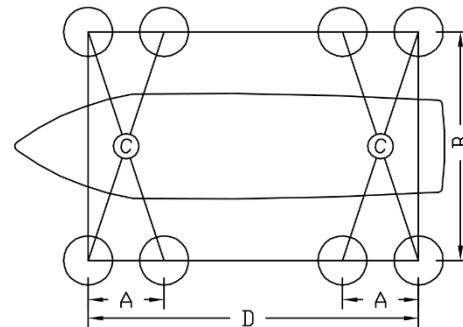

Travel Specifications

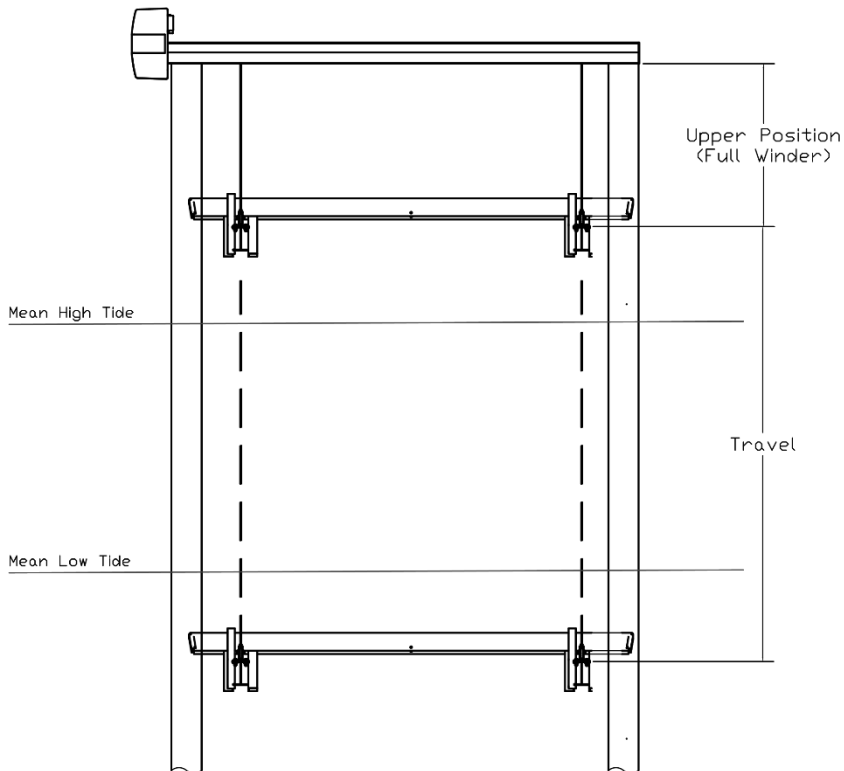

LIFT CAPACITY lbs.	LIFT TRAVEL ft.	UPPER POSITION WITH FULL WINDER ft.	STANDARD CABLE LENGTH ft.
4,500	14	4	20
7,000	14	4	20
10,000	12	6	38
13,000	12	6	38
16,000	12	6	38
20,000	12	6	60
27,000	12	6	74

The **Upper Position** is the distance between the top beam and cradle beam with a full winder and the remaining cable routed through all pulleys and the wedge lock. This distance can easily be lessened by pulling more cable through the wedge lock. Note, do not make this distance less than two feet with your cable adjustments.

The lift **Travel** is determined by the size of the winder and represents the length of cable in a full wrapped winder. The relative vertical position of this fixed travel can be adjusted by changing the length of the cables. Larger custom winders can be ordered when increased Travel is required.

When determining the Travel requirements for your lift, you need to consider the height of the piles, mean high tide, mean low tide and the draft of the boat. At high tide, the upper position needs to be such that the cradles are out of the water. At low tide, the Travel needs to be large enough that the cradles can lower below the boats draft allowing the boat to float off the lift.

Preparing Piles for Installation

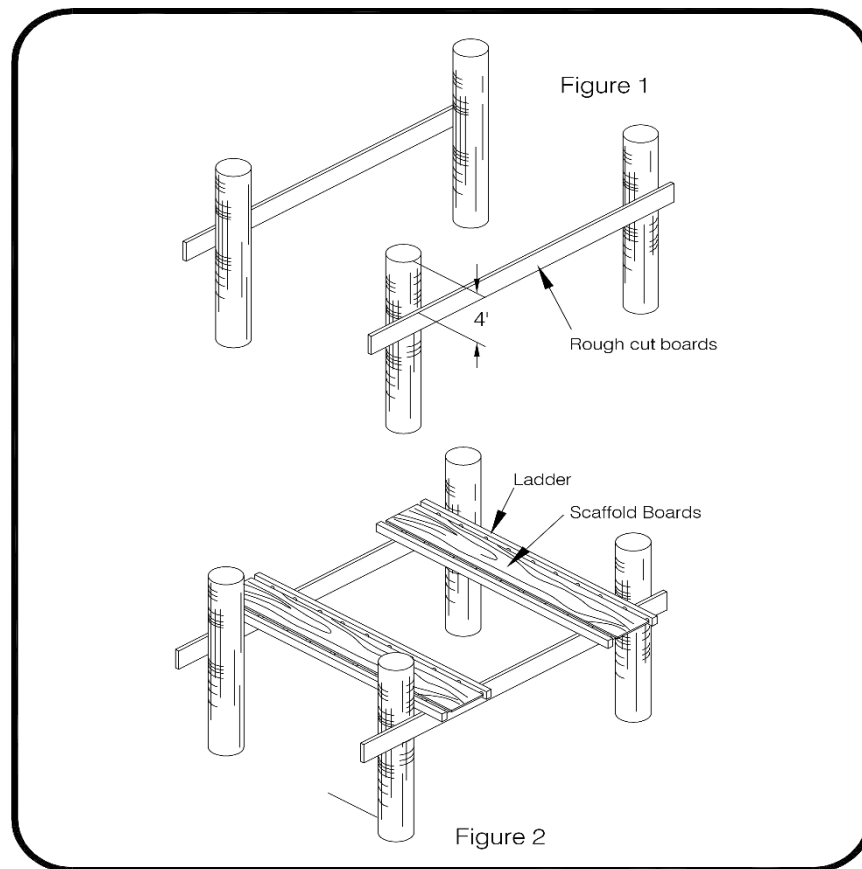

- To scaffold the pilings, nail a 2"x8"x16' board across 2 piles, approximately four feet below the top of the piles (Fig. 1). Repeat for remaining two piles.
- Place the two 18' sections of extension ladder across the boards with (2) 1"x6"x16' scaffold boards on top of each ladder section as shown in Fig. 2.
- Measure the desired height of the pilings above the surface of the water and mark all (4) pilings at the same height. Note: mark all (4) pilings at desired height and confirm the shortest piling is at or above this height before cutting.
- Cut all pilings to the measured mark.
- Level all piling tops to assure solid seating of the cable beams.

Mounting Top Beam to the Piling

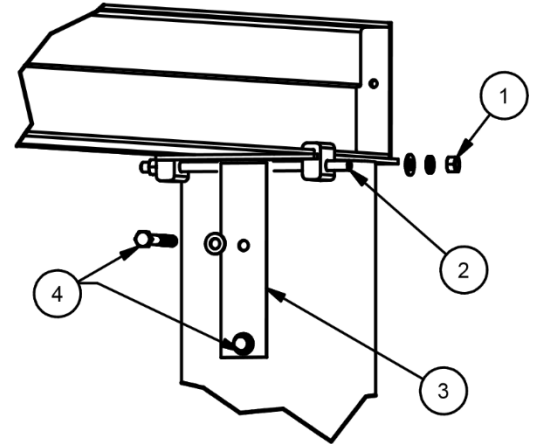
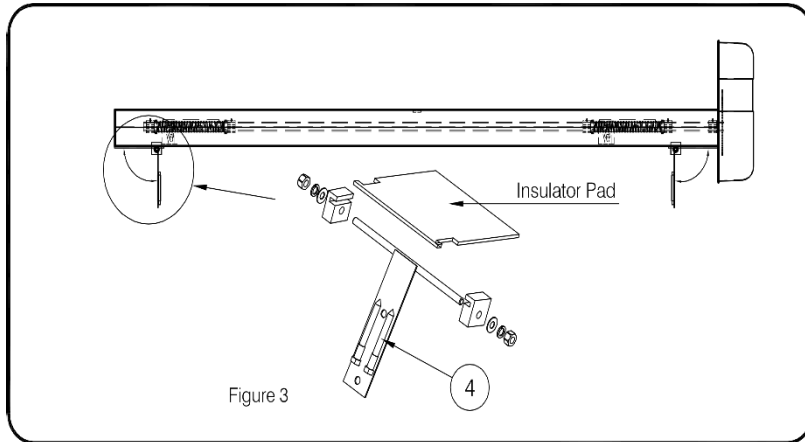

- The universal piling mounts are pre-assembled on all our lifts.
- The pile mounting plates come folded up, parallel with the top beams for shipping. Loosen the nuts (1) at the end of the threaded shaft (2), then swing the pile mounting plates (3) down so they are perpendicular to the top beams.
- Position the beam on top of the pilings making sure the insulator pad is between the top beam and pile. Aluminum reacts with the chemicals in pressure treated piles and the insulator pad is essential to protecting the top beam.
- Remove the lag screws (4) and hardware that comes attached to each mounting plate.
- With the pile mounting plates (3) flush to the pile, mark the location for the lag screws. Drill two 3/16" x 4-1/2" deep pilot holes at each pile to correspond to the holes in the mounting plate.
- Secure with the 3/8" stainless steel lag screws and hardware. Tighten all hardware on universal piling mount.

Cable Installation

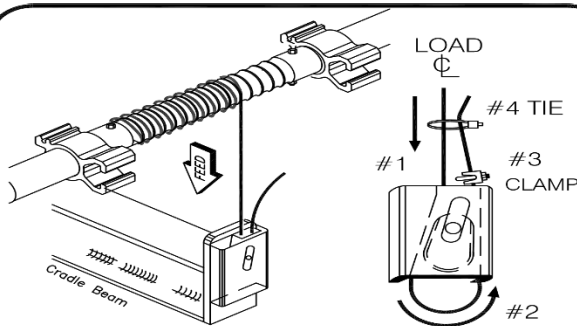

Figure 6 1 Part Cable System

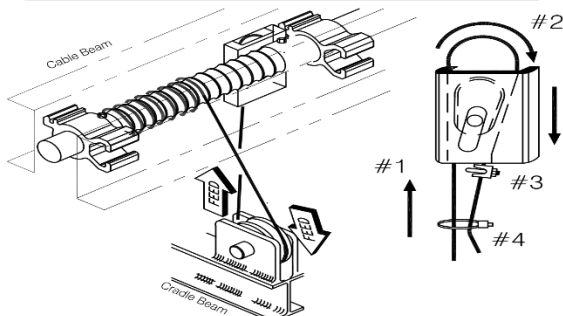

Figure 7 2 Part Cable System

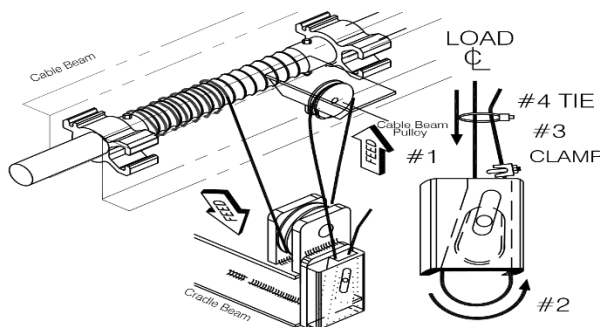

Figure 8 3 Part Cable System

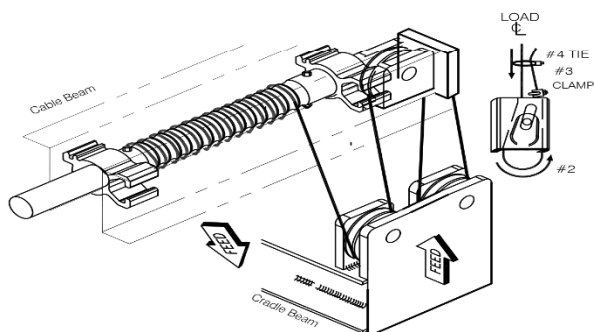

Figure 9 4 Part Cable System

1 PART SYSTEM (Fig. 6)

- Feed loose end of cable down the center of the wedge lock.
- Loop around wedge (inside lock) and return up through lock.
- Leave about 12" of free cable tail

2 PART SYSTEM (Fig. 7)

- Thread cable through pulley and return to top beam.
- Feed cable up and through the lock, loop around the wedge and pull cable down through the lock.
- Leave about 12" of free cable tail.

3 PART SYSTEM (Fig. 8)

- Thread cable through pulley at cradle beam.
- Draw cable up and around top beam pulley.
- Thread cable down to wedge lock.
- Feed cable down the center of the lock, loop around the edge and return up through the lock.
- Leave about 12" of free cable tail.

NOTE: Do not let cables overlay each other.

4 PART SYSTEM (Fig. 9)

- Thread cable through the pulley closest to the winder on the cradle beam.
- Draw cable up and around top beam pulley.
- Thread cable down and around remaining pulley on the cradle beam.
- Feed cable up to the wedge lock on top beam.
- Loop around wedge and pull down through the lock.
- Leave about 12" of free cable tail.

ADJUST and LEVEL

- Level cradle beams by adjusting cable length using wedge lock.
- Adjustments are made by loosening wedge and pushing the cable through.
- Fasten clamp to cable tail. **DO NOT** clamp tail and cable together.
- Wire tie the free cable tail to load cable. Trim excess cable leaving a minimum 6" of free cable.

Bunk Board and Guide Post Installation

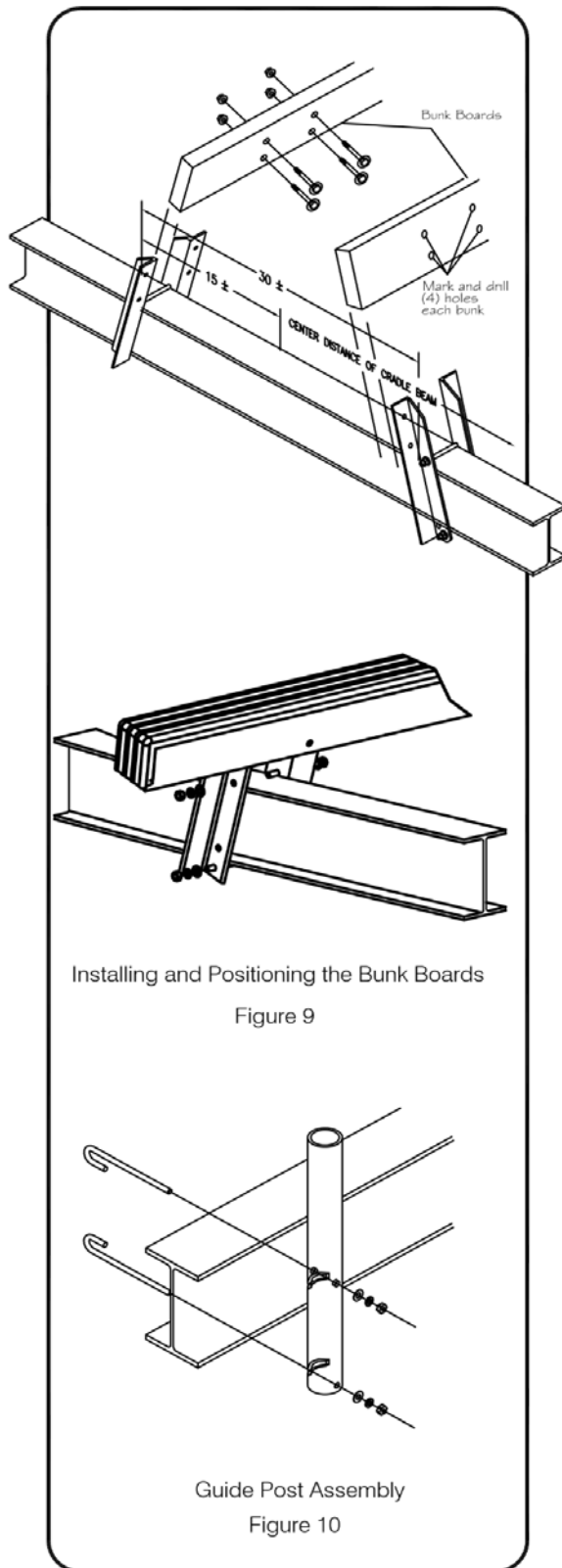

Installing and Positioning the Bunk Boards

Figure 9

Guide Post Assembly
Figure 10

BUNK BOARD MOUNTING ASSEMBLY (Fig. 9)

- The bunk brackets have been pre-installed on the cradle beams. The brackets may be repositioned by loosening the nuts at the bracket and sliding along the cradle beam. Typical dimensions are 30" apart centered on the cradle beams.
- Center the bunk boards across the cradle beams with even overhangs on each side.
- Make sure the bunk boards are flush to the cradle beams and the bunk brackets.
- Mark, then drill (8) ½" diameter holes for mounting the bunk boards to the bunk brackets.
- Attach the bunk boards with the supplied stainless steel bolts and hardware.

LIFTS WITH ALUMINUM BUNKS

- The aluminum bunks come with mounting brackets pre-installed.
- Center the aluminum bunks on the cradle beams and attach with the supplied stainless steel bolts and hardware.

GUIDE POST ASSEMBLY (Fig. 10)

- The guide post brackets come pre-installed on the cradle beams. The brackets may be repositioned by loosening the nuts on the "J" bolts and sliding along the cradle beam.
- Measure the beam of the boat to be lifted, and fit the guide post brackets to the beam of the boat so that they are centered on the cradle beams.
- Install guide post pipe insert into the brackets and slide PVC protective sleeve over the pipe.
- With boat positioned on the lift, make final adjustments to the fit of the guide posts and then tighten bracket hardware.

Boat Lift Electrical Requirements

Having the proper electrical service to the boat lift is critical to the performance of the lift. Inadequate electrical service could result in damage to the motor and / or the lift controls. When at all possible, the boat lift should have dedicated electrical service to prevent circuit overloading and to minimize interference by other devices on the circuit. Consult the following chart as minimum guidelines for properly sized circuit breaker and wire size based on horsepower and number of motors.

Minimum Breaker and 75C Copper Wire Size (AWG) for Single-Phase A.C. Motors

# and Motor H.P.	Amps to run		Breaker Size		50 Feet		100 feet		200 feet		300 feet		400 feet	
	115V	230V	115V	230V	115V	230V	115V	230V	115V	230V	115V	230V	115V	230V
(2) 3/4 H.P.	23	12	30 A	15 A	#8	#14	#6	#12	#3	#8	#2	#6	#1	#6
(2) 1 H. P.	----	14	----	20 A	----	#14	----	#10	----	#8	----	#6	----	#4
(2) 1 1/2 H.P.	----	18	----	25 A	----	#12	----	#10	----	#6	----	#4	----	#4
(4) 1 H.P.	----	28	----	35 A	----	#8	----	#8	----	#4	----	#4	----	#3
(4) 1 1/2 H.P.	----	36	----	45 A	----	#6	----	#6	----	#4	----	#3	----	#2

Important Notes:

- Please use current motor label to confirm specifications in above chart.
- For Aluminum wire, increase by 1 wire size, minimum.
- The wiring recommendations and diagrams referred to are not meant to supersede any national or local codes.
- Read all instructions and wiring diagrams before connecting or changing wires.
- The appropriate instructions and wiring diagrams are enclosed in the control box.
- Imm Quality Boat Lifts recommends that all electrical work be performed by a licensed electrical contractor.
- Wiring procedures other than those presented by Imm Quality Boat Lifts will void the product warranty.

ELECTRICAL: MOTOR WIRING

BONITA, GEM, AND TIGERSHARK CONTROLS

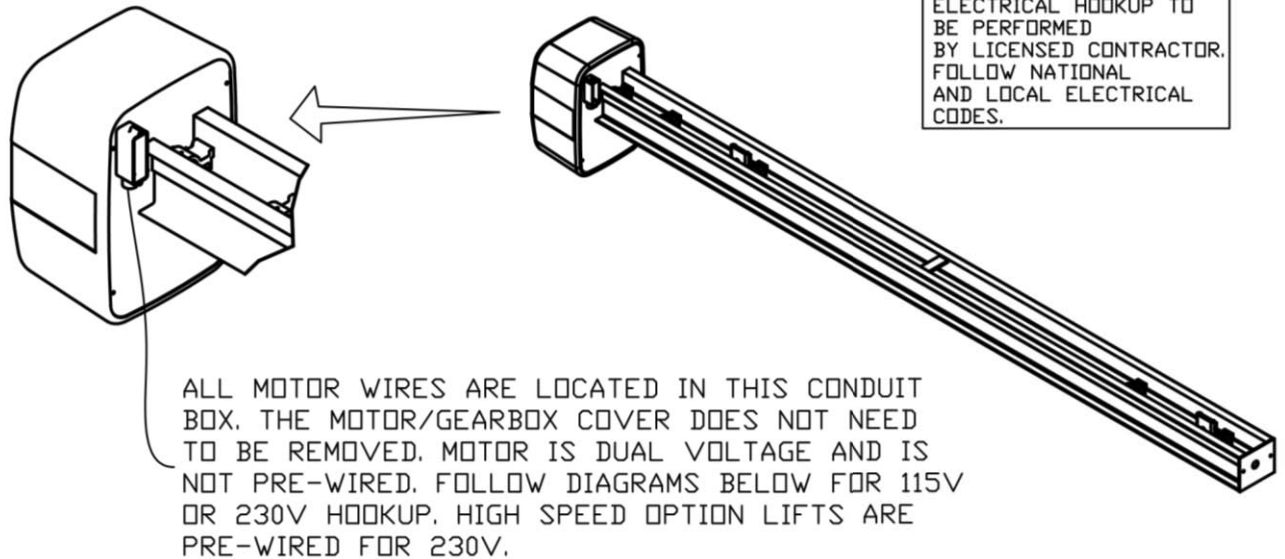

* CONSULT MANUAL WITH THE SUPPLIED CONTROL BOX FOR SPECIFIC WIRING INSTRUCTIONS

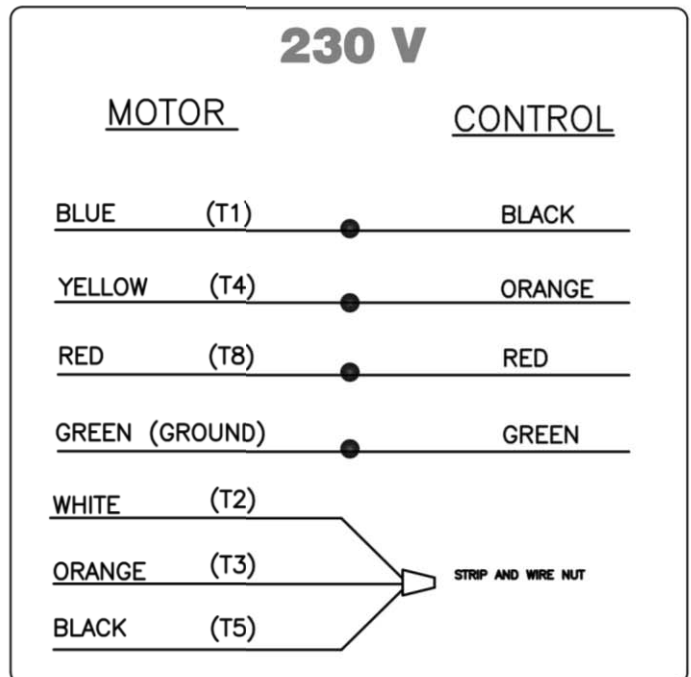
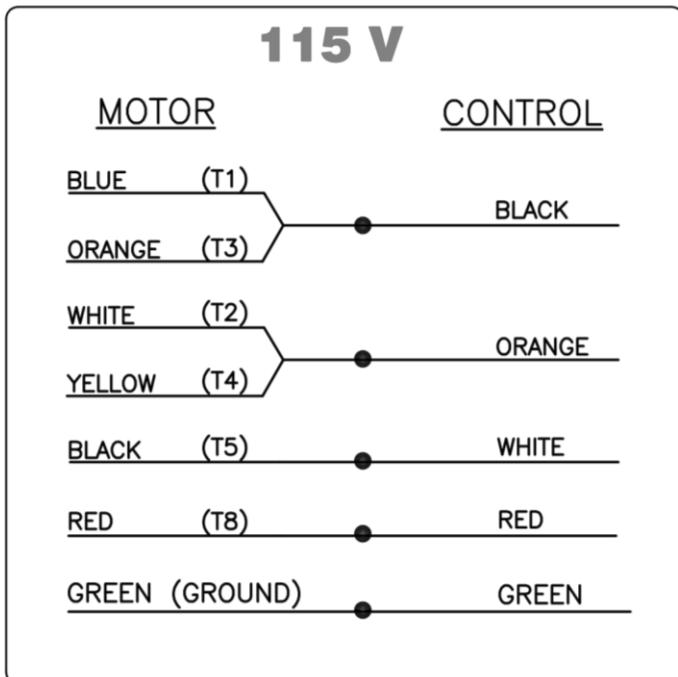

* TO REVERSE MOTOR DIRECTION FOR EITHER VOLTAGE INTERCHANGE BLACK (T5) AND RED (T8)

