

IMM QUALITY

— BOAT LIFTS —

Owner's Manual

For

Trident

Boat Lifts



SAFETY PRECAUTIONS



1. Your boat lift is a heavy duty piece of equipment. It is important that all persons that may operate this unit have read and understood the owner's manual. Given the inherent dangers of heavy machinery, your boat lift deserves respect, and good judgment is required in its operation. Before allowing others to operate the unit be certain that they understand the proper operating procedures. Do not allow children to operate the lift.
2. This product is for lifting unoccupied boats. Do not ride in your boat or on the lift during operation. Always attend the controls when operating the lift, and watch carefully to have others stand clear. Keep hands, feet, and clothing away from all moving parts.
3. Your lift is operated by electricity, therefore, additional care must be taken. It must be wired by a licensed electrician, and it must be installed with an approved ground fault interruption device. If you observe severed or damaged wiring, it must be repaired immediately by an electrician. When properly installed and maintained, electrical devices such as this lift are completely safe. However, any electrical device used in and around a water environment must be treated with great respect to prevent accidental electrocution. All electrical maintenance and service to this lift must be done by a licensed electrician.
4. While operating your lift, routinely look at all cables for fraying, damaged ends, or loose strands. A damaged cable must be replaced immediately. Make sure that all pulleys are turning properly. Routinely look over cables to make sure that they are winding properly. Look for signs of extreme wear and unusual corrosion, as well as, exposed or damaged electrical wires. If you find any of the above, have the problem repaired immediately.
5. Do not work on your boat or lift while the boat is hoisted. When working on your lift, keep your hands, feet, and clothing away from all moving parts. Exercise great care if chains or gearing are exposed. Never work underneath a raised lift, and do not walk or stand on a raised lift. Always disconnect electrical power when working on any part of the lift.
6. Be careful not to exceed the rated capacity of the lift. To determine the total weight of your equipment to be lifted, study the boat manufacturer's literature to determine its weight. Be sure to add enough extra weight to compensate for your added accessories, including water and fuel. Gasoline weighs about 6 lbs. per gallon and water weighs about 8 lbs. per gallon.
7. If you plan to leave your lifted boat unattended for several weeks, it is important that you remove the drain plug in the boat to prevent it from filling with rain water. Accumulated rain, snow or other water in your boat can rapidly become heavy enough to exceed the capacity of a lift, causing personal injury or damage to the boat and lift.

Congratulations on your purchase of an Imm Quality Trident Boat Lift! We appreciate your business and want you to know that you have purchased the finest boat lift on the market today. We believe our lifts are the easiest to use on the market today and are confident that your new lift will provide many years of trouble free use. This Owner's Manual is designed to provide vital safety information on your lift, as well as the necessary information for lift maintenance and instructions on its use. Again we thank you for your business and you can rest assured knowing your boat is cradled by Imm Quality Boat Lifts.

Built For A Lifetime!

Table of Contents

	Page
Figure of Lift Components	4
Boat Positioning	5
Operating Instructions	6
Helpful Hints	7
Maintenance Instructions	9
Maintenance History	10
Figure of Lift Accessories	11
Imm Quality Boat Lifts Warranty	13
Records Page	16
Product Registration Form	17

Components:

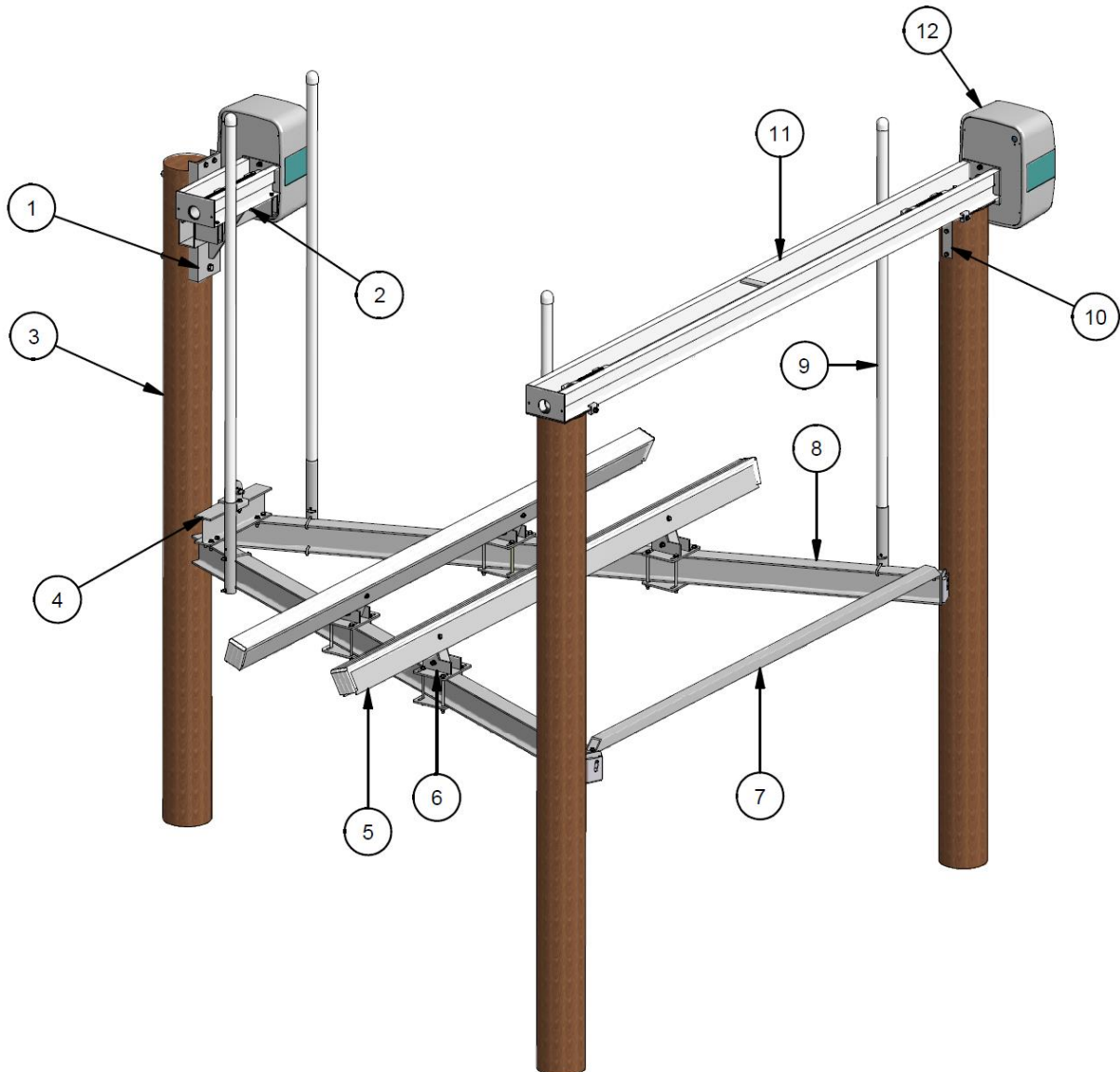

- | | |
|--------------------------|--------------------------|
| 1. Pile Mount Channel | 2. Cable Beam, Short |
| 3. Pile | 4. Cradle Beam Connector |
| 5. Bunk & Cover Assembly | 6. Slotted Bunk Brackets |
| 7. Cable Spreader Tube | 8. Aluminum Cradle Beam |
| 9. Guide Post Assembly | 10. Pile Mount Strap |
| 11. Cable Beam, Long | 12. Powerhead |

Boat Positioning:

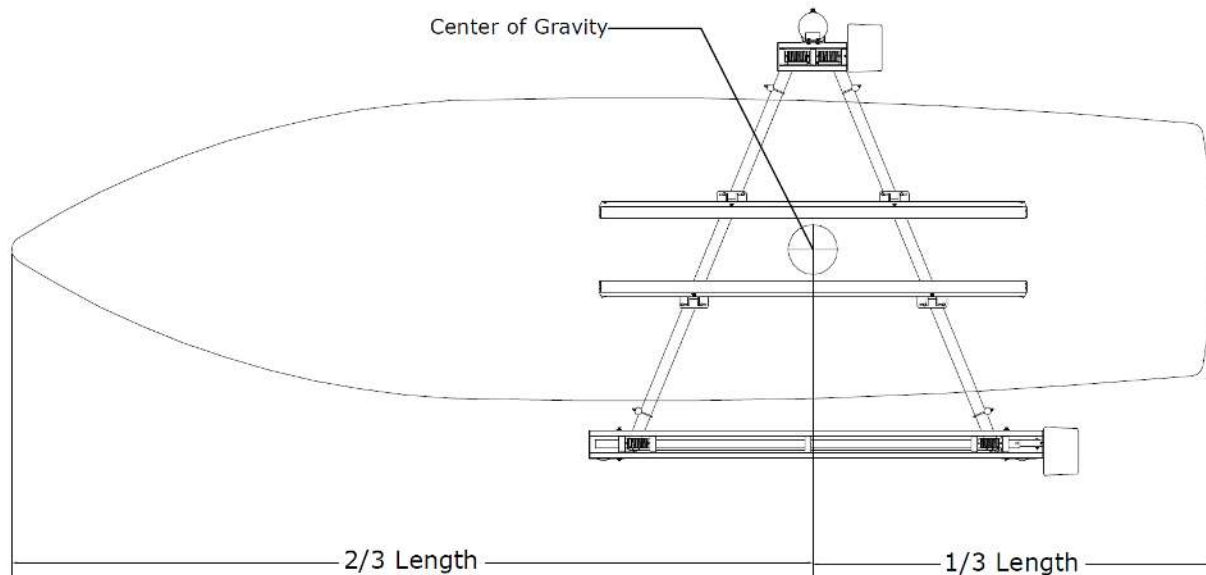

Position boat on lift as shown so that the center of gravity is centered between the cradles. Most boats are heaviest in the stern, thus the cradle beams will generally be positioned more toward the stern of the boat. Some boat manufacturers can provide you with the fore and aft position of the center of gravity. Ask your boat dealer for such information.

To properly locate your boat fore and aft on the lift when center of gravity information is unavailable, you can use a trial and error method commonly employed by marine contractors. With the boat on the lift in approximately the correct position, raise the lift until the cradle beams clear the water by a few inches. Using a hammer, wrench or small pipe, tap the cable on the fore cradle beam and listen to the pitch of the sound. Do the same to the cable on the aft cradle beam, making sure to strike at approximately the same height above the water as with the fore cable. The cable with the highest pitch sound is the tightest, and therefore is carrying the heaviest load. Lower the lift and reposition the boat towards the lower pitched cable. Repeat as necessary until both cables have the same pitch. Once established, it is a good idea to mark the proper fore and aft position on the hull so that it can be repeatedly aligned with a corresponding mark on the dock or lift.

Operating Instructions

Upon completion of your lift installation, the contractor will adjust the bunks and guide posts to fit your boat. Familiarize yourself with the control system instruction label located on your lift. Never leave the lift unattended while in operation. Be sure the boat stays level when raising or lowering the lift. Failure to shut off the lift will result in major damage to the lift and / or boat.

To **lower** the lift:

1. Turn power on to the lift.
2. Set switches in “down” position and allow the lift cradle to sink into water deep enough to float the boat so that boat hull and props are clear of the lift. Make sure you do not lower the lift so much that it touches bottom and causes the cables to go slack as this can cause the cables to tangle or to rewind irregularly. If the cables go slack, be sure to realign and tighten cables before lifting the boat.
3. Turn power off to the lift.

To **raise** the lift:

1. Turn power on to the lift.
2. Float your boat into centered pick-up position. The guide posts will automatically center your boat side-to-side over the bunks. **Do not power the boat onto the lift cradle as this will result in damage to the lift and / or boat.**
3. Set switches in “up” position and stand in center of boat.
4. As soon as you feel the bunks contact the boat, set switches to “off” position and get off the boat.
5. Continue to raise the boat by setting switches to the “up” position. When boat has reached your desired height above the water, set switches to “off” position. To make sure that the cables wind properly, it is recommended that the cradle beam on a fully lifted boat be no closer than two feet from the top beam.

6. Turn power off to the lift. We recommend turning power off to the lift when you are not boating as a safety precaution, both to prevent accidental lift operation and to prevent the theft of your boat.

Your lift was designed for many years of trouble free use. When properly installed, your lift is designed to lift your boat high enough to prevent flotation during tidal surges and unusual weather conditions. Take care not to leave the cradle beams submerged for extended periods of time after lowering your lift. Marine life can adhere to cables, the structure and moving parts causing extensive wear or malfunction. Salt water and brackish water are also very corrosive to metals. Your lift is designed to operate for many years in this highly corrosive environment, if reasonable precautions are taken. It is recommended that you do not leave cradle beams underwater more than a few hours in salt or brackish water.

Helpful Hints

How can I establish a repeatable submerged depth for my lifts that will allow my boat to float on to and off the bunks?

You will want the position of the bunks to be deep enough in the water to allow the boat to readily float over them. Returning to your lift after a tide change can cause you to question whether or not there is enough flotation clearance above the bunks. To mark your lift so that you can visually determine the proper depth of the cradles; 1. Lower the lift until your boat floats. Then lower it a few more inches. 2. While the lift is in this position, mark one or more of the guide posts with a pencil at the water line. 3. Raise the lift to a height where it is easily accessible. 4. After the guide posts have dried sufficiently, either paint a stripe around the guide post at the pencil mark or wrap with electrical tape. No matter the tide, as long as your mark is below the water level, you will be able to float your boat onto the cradles.

If I buy a new boat how does it affect my lift?

First, make certain that your new boat does not exceed the rated capacity of your lift. The capacity of the lift can be found on the yellow label on one of the cable beams, and is also a part of the model number. For example, an Alumavator model 10,000 has a rated capacity of 10,000 pounds. At a minimum, you must add at least 20% to the manufacturer's dry weight of the boat to allow for fuel and water weight. Also include the weight of any accessories the boat will have. Finally, you may need to adjust the bunks to accommodate a different hull and it may be necessary to move the guide posts.

What is the power requirement of a boat lift?

We recommend all boat lifts be wired 240 volt with at least 30 amp service available at the dock. Lifts using $\frac{3}{4}$ hp and $\frac{1}{2}$ hp motors may be wired 120 volt with 20 amp service at the dock. You will obtain the best service life from your motors by providing adequate voltage and amperage. Most electrical problems are caused by inadequate shore power to the lift. Please refer to the wiring diagrams provided with the installation manual.

What should I do if a hurricane approaches?

The best solution is to remove the vessel from the boat lift and secure it safely on dry land. A boat lift is only as strong as the pilings it sits on, so no boat lift is hurricane proof. Also your boat lift could have a collision from other vessels or major debris. If you are left with no other choice but to leave the vessel on the lift, secure the boat to the fixed portion of your lift. Imm Quality Boat Lifts suggests the following to support the safety of your vessel before, during and after a storm: 1) Raise the lift as high as possible without double wrapping the cable or winding beyond the winding area. 2) With the boat tipped slightly to the stern for drainage, tie straps from the inboard pilings to the outboard pilings over the top of your boat but under the railing. Use the lift to hold the boat tightly against the straps. This procedure will lock the boat in place making it more resistant to wind. Do not secure the boat to the cradle system. Heavy wind will cause the boat and cradles to bounce up and down on the cables, likely breaking the cables in the process. 3) Make sure power is turned off including the breaker supply in the

house. If at all possible, remove the motors and controls to prevent failure from flooding. 4) Remove all loose materials from the vessel, including cushions that are snapped in place. Put all antennas and outriggers down if they cannot be removed. 5) If you're not in a high water area, remove the drain plug or make sure the bilge pump is on and working so the boat doesn't flood with water and overload the boat lift. 6) Make certain you have all of your vessel's paperwork in order, including registration, it may be needed for an insurance claim.

Maintenance Instructions

Imm Quality Boat Lifts prides itself on building extremely durable and low maintenance lift systems. To keep your lift operating at peak performance, we recommend that you operate your lift occasionally during the off-season, or extended periods of no boating activity. Simply run the lift for one minute in each direction. This will keep the motor contacts and brushes clean and the lubricant evenly distributed in the gear box. In addition, **please perform the following routine maintenance at least twice a year.**

- Inspect pulleys for wear and make sure they are turning properly. Our pulley bearings are maintenance-free, no lubrication is necessary.
- Inspect all cables for fraying, damaged ends, loose strands, and to see if they are winding properly. Replace cables immediately if frayed, kinked or damaged.
- Cables need to be replaced every two years, or every 350 lift cycles, whichever comes first.
- Watch for signs of extreme wear and corrosion. If observed, contact Imm Quality Boat Lifts service department or your dealer contractor.
- The drive pipe bearings are maintenance-free, no lubrication is required.
- The Trident lift's Platinum Drive is maintenance-free. No adding or changing lubrication is necessary.

Maintenance History

Date	Maintenance Performed	By

Lift Accessories

Imm Quality Boat Lift's high performance accessories are made from the finest materials and are durable and easy to use. If you have any questions about our accessories, call us toll-free at 1-800-545-5603 and one of our experienced sales technicians will be happy to assist you.

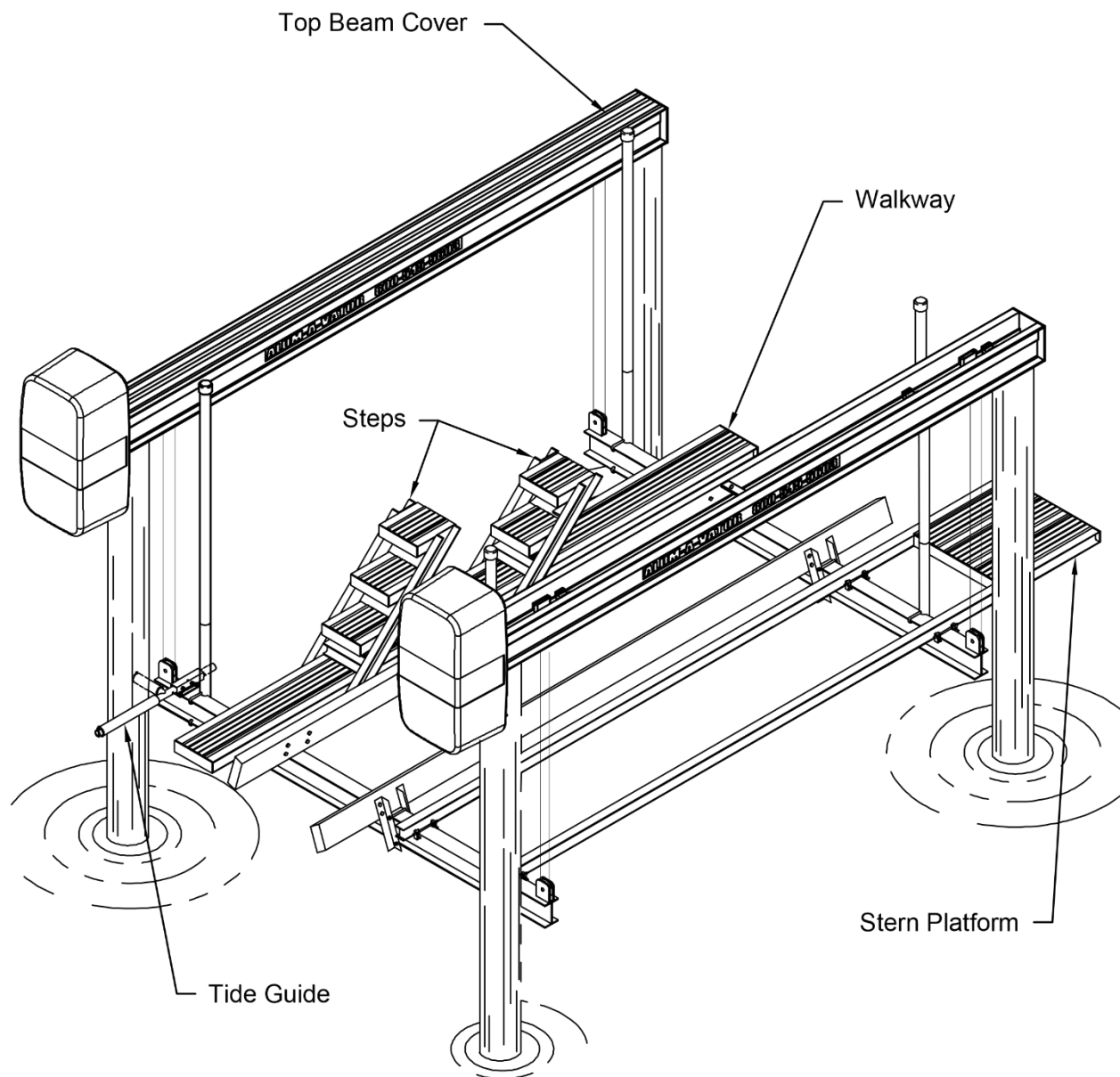

Some of our accessories include:

Top Beam Covers: Non-skid cover allows the top beam to be used as a boat-side step in low-profile installations. Not Applicable to beamless lifts.

ThruFlow Decking: Cover all or part of your cradle with ThruFlow decking.

Walkways: Mounted adjacent to the boat on one or both sides of the lift, walkways provide easy access for hull cleaning.

Steps: Available in 2, 3, 4, or 5 step configurations, with or without handrails, steps provide easy access to larger watercraft from walkways.

Stern Platform: Allows access to your boat's stern, enabling you to flush your engine or work on your lower drive unit.

Hinged Access Platforms: A platform that is capable of folding up. Particularly useful with elevator lifts.

Tide Guides: Stabilizes your lift's lower cradle system during approach and entry, especially useful in turbulent or strong current conditions.

Rotary Limit Switches: Offers the added convenience of presetting upper and lower travel limits for your lift.

Control Options: Manual, remote and auto-stop. Raise or lower your boat from a distance with radio controls.

Upgraded Motors: Stainless steel construction provides salt water protection.

Solar Package Kits: If you are unable to get power at the lift, this option makes using a lift possible. The environmentally friendly option.

And many more! Please visit our website www.iqboatlifts.com



17030 Alico Center Rd.
Fort Myers, FL 33967
Toll Free 1-800-545-5603
Phone: (239) 432-9110
Fax: (239) 432-0019

Limited Warranty

Imm Quality Boat Lifts warrants our boat lifts as follows:

1. With respect to lifts purchased or used for personal, family or household purposes, Imm Quality Boat Lifts (the "Company") warrants the structural integrity of the aluminum cradle beams and top beams of our 4 and 8 post boat lifts for a period of 15 years from the date of delivery to the original owner.
2. With respect to lifts purchased or used for personal, family or household purposes, Imm Quality Boat Lifts warrants the structural integrity of the aluminum carriage arms and cradle beams of our elevator and PWC boat lifts for a period of 5 years from the date of delivery to the original owner.
3. The Company further expressly warrants that lifts purchased or used for personal, family or household purposes shall be free from manufacturer's defects in material and workmanship for a period of 5 years on gear boxes, 2 years on all electrical motors and 1 year on all other components from the date of delivery to the original owner. Our underwater tracks and hardware are warranted for a period of 1 year from defects in material and workmanship with the following limitations: Sacrificial anodes must be maintained and an electrical disconnect, including neutral and ground, must be provided or warranty will be null and void. Under no circumstances will the warranty coverage extend to damage caused by electrolysis or corrosion.

The Company agrees to provide all necessary parts and materials only (no labor) to correct any warranted defect during warranty periods described above; provided Imm Quality Boat Lifts receives notice of any such defects within the applicable specified warranty periods.

What is not covered by this warranty:

1. If the equipment is installed at any location other than the original purchaser's address specified in the sales agreement all warranties express or implied are null, void, unenforceable and the equipment shall be deemed sold "as is" with the entire risk to quality and performance to be borne by owner.
2. The Company makes no express or implied warranties with respect to lifts purchased or used for commercial purposes. The Company makes no express or implied warranty of merchantability or fitness for any particular purpose.

3. Damage which is caused by improper product selection, improper installation, failure to follow applicable installation and maintenance recommendations, or failure to follow applicable instructions or warnings are not covered by this Limited Warranty.
4. Damage that is not the Company's fault, such as, but not limited to, damage caused by accidents, misuse, overloading, negligence, alteration, modification, or abusive operation is not covered by this Limited Warranty.
5. The Company shall not be responsible for any incidental or consequential damage, including, but not limited to, damage to property, loss of use, lost profits, or expenses for inconvenience.
6. All repairs after the applicable warranty period are the Owner's responsibility.
7. All routine maintenance and periodic service is the Owner's responsibility and is not covered by this Limited Warranty.
8. If the original Owner or any one not authorized by Imm Quality Boat Lifts attempts to make repairs to the lift, all warranties express or implied are null, void, unenforceable and the equipment shall be deemed sold "as is" with the entire risk to quality and performance to be borne by owner.

This warranty further does not cover any damages whatsoever including incidental and / or consequential damages resulting from any adverse weather conditions, acts of God or other causes not due to a defect in materials and / or workmanship of our product.

Warranty Disclaimers:

1. Any applicable implied warrant, including any applicable warranty of merchantability or fitness for a particular purpose, is limited to a period of 2 years from the date of delivery to the original purchaser.
2. The Company makes no express warranties regarding its products except as stated herein. No agent, employee, or representative of the Company has authority to bind the Company to any affirmation, representation, or warranty concerning the Company's products except as stated herein.
3. Some states do not allow the exclusion or limitation of incidental or consequential damages nor do some states limit the length of implied warranties, so the above limitations may not be applicable to all owners.

It is the responsibility of the Owner to ensure that each product is fit for its' intended purpose, to ensure the intended location is suitable for the lift, and to ensure that the installation is completed according to Imm Quality Boat Lift's recommendations described in the installation manual. The Owner acknowledges that all users must understand how to operate the lift in a safe manner. The Owner acknowledges the need for regular service and maintenance of the lifting equipment by a qualified technician which is not covered by warranty.

The Owner's remedies under the Limited Warranty are limited exclusively to repair or replacement of components which fail due to manufacturer's defects in material or workmanship during normal operation.

If you have any questions or problems:

1. Should the Owner encounter a problem which might be covered by this Limited Warranty, the Owner must contact the Company in writing within the applicable warranty period. Imm Quality Boat Lifts address for receipt of notice is:

17030 Alico Center Rd., Fort Myers, FL 33967

2. The Owner should provide the following information in their written notice: the type of product purchased, the purchase date, event dates, dealer name, the problem or question along with any other pertinent information.

This Limited Warranty gives you specific rights, and you may have other rights which vary from State to State.

This Limited Warranty shall be governed by and construed in accordance with the internal laws of the State of Florida, U.S.A., without reference to any conflicts of law provisions.

The Owner hereby submits to the exclusive jurisdiction of, and waives any venue or other objection against, any court of competent jurisdiction sitting in Lee County, Florida for any legal proceeding arising out of or relating to this Limited Warranty. Each party agrees that all claims and matters may be heard and determined in any such court and each party waives any right to object to such filing on venue, forum non-conveniens, or similar grounds.

For your Records

LIFT MODEL _____

CAPACITY _____

SERIAL NO. _____

DATE OF PURCHASE _____

CONTRACTOR _____

PHONE NO. _____

ELECTRICIAN _____

PHONE NO. _____

Note: Retain your sales slip; it is your proof of purchase.

Imm Quality Boat Lifts is always striving for perfection. Unfortunately, it is not practical to reprint our brochures and product literature every time we make an improvement, therefore, specifications may change at any time without notice. We make every effort to know and recommend the various Marine Contractors that sell and install our products. It is our goal that these contractors operate in a professional and ethical manner. However, we cannot be held responsible for any work or consequences of any work not performed by Imm Quality Boat Lifts.



17030 Alico Center Rd.
Fort Myers, FL 33967
Toll Free 1-800-545-5603
Phone: (239) 432-9110
Fax: (239) 432-0019

Product Registration

PLEASE FILL OUT AND MAIL WITHIN 30 DAYS OF LIFT INSTALLATION TO OUR ADDRESS

Imm Quality Boat Lifts
17030 Alico Center Rd.
Fort Myers, FL 33967

NAME _____

ADDRESS _____

CITY _____ STATE _____ ZIP _____

PHONE _____

LOCATION OF LIFT (if different than above)

LIFT MODEL _____ CAPACITY _____

SERIAL NO. _____ DATE INSTALLED _____

CONTRACTOR _____ PHONE _____

ELECTRICIAN _____ PHONE _____

MAKE AND MODEL OF BOAT _____

I have read the owner's manual and understand the use of my lift and any precautions to be taken.

Signature _____ Date _____

